

VEGETATED BIOSWALE CROSS SECTION
NTS

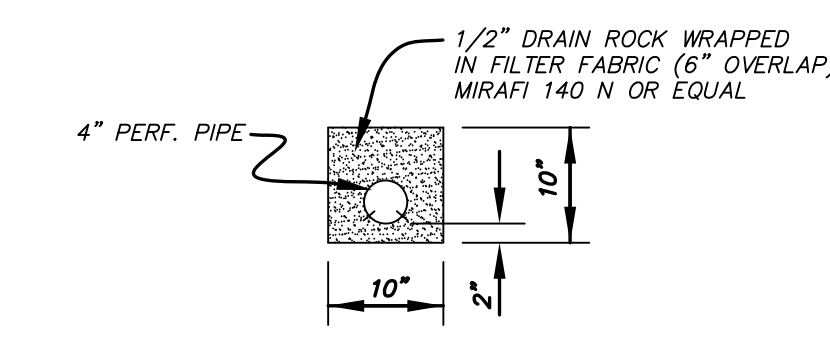

TRENCH DETAIL
NTS

NORTH SIDE VEGETATED BIOSWALE

DMA NAME	AREA	DMA & IMP SIZING FACTOR	BMP AREA REQUIRED
CONDOMINIUM ROOF	8,538 SF	(1.00 x .04)	= 342 SF
PAVED WALKWAY	1,508 SF	(1.00 x .04)	= 60 SF
LANDSCAPING	2,920 SF	(0.10 x .04)	= 12 SF
			= 414 SF MIN. REQ'D. VEGETATED BIOSWALE
			425 SF VEGETATED BIOSWALE PROVIDED

SOUTH SIDE VEGETATED SWALE

DMA NAME	AREA	DMA & IMP SIZING FACTOR	BMP AREA REQUIRED
RESIDENTIAL ROOF	1,065 SF	(1.00 x .04)	= 42 SF
PAVED WALKWAY	768 SF	(1.00 x .04)	= 31 SF
LANDSCAPING	2,442 SF	(0.10 x .04)	= 10 SF
			= 83 SF MIN. REQ'D. VEGETATED BIOSWALE
			100 SF VEGETATED BIOSWALE PROVIDED

- LEGEND**
- T = TREE (APPROXIMATE DIAMETER)
 - AP = ANGLE POINT
 - BC = BUILDING CORNER
 - C = TOP OF CURB
 - CL = CATCH BASIN
 - CONC = CENTER LINE
 - DI = CONCRETE
 - DL = DAYLIGHT
 - DW = DRIVEWAY
 - F = FENCE
 - FL = FLOW LINE
 - GB = GRADE BREAK
 - GL = GUTTER LIP
 - GM = GAS METER
 - GP = GATE POST
 - GR = GROUND ELEVATION
 - HB = HOSE BIB
 - INV = INVERT
 - M&M = MAP & MEASURE
 - P = PAVEMENT
 - PBB = PACIFIC BELL BOX
 - POE = PACIFIC GAS AND ELECTRIC BOX
 - POC = POINT ON CURVE
 - RET = RETURN
 - SIGN = SIGN
 - SD = STORM DRAIN LINE
 - SDMH = STORM DRAIN MANHOLE
 - SS = SANITARY SEWER LINE
 - SSMH = SANITARY SEWER MANHOLE
 - SSCO = SANITARY SEWER CLEAN OUT
 - T = TOP OF SLOPE
 - TOC = TOP OF CONCRETE
 - TW = TOP OF WALL
 - TUB = TELEVISION UTILITY BOX
 - W = BACK OF WALK
 - WLK = WALK
 - WM = WATER METER
 - WV = WATER VALVE
 - = MONUMENT LINE
 - - - = PROPERTY LINE

GENERAL NOTES

- THE LOCATIONS OF UNDERGROUND UTILITIES AS SHOWN HEREON ARE BASED ON ABOVEGROUND STRUCTURES AND RECORD DRAWINGS PROVIDED THE SURVEYOR. LOCATIONS OF UNDERGROUND UTILITIES/STRUCTURES MAY VARY FROM LOCATIONS SHOWN HEREON. ADDITIONAL BURIED UTILITIES/STRUCTURES MAY BE ENCOUNTERED. NO EXCAVATIONS WERE MADE DURING THIS SURVEY TO LOCATE BURIED UTILITIES/STRUCTURES.
- CONTRACTORS AND OTHERS PERFORMING WORK SHALL VERIFY THE EXACT LOCATION AND DEPTH OF ALL UNDERGROUND UTILITIES.
- SPRINKLER HEADS AND IRRIGATION LINES ARE NOT SHOWN HEREON.
- CONTOUR INTERVAL = 2'
- ELEVATIONS ARE ON AN ASSUMED DATUM.
- BASIS OF BEARINGS: THE BEARING N 29° 00' 00" W BETWEEN THE TWO STANDARD STREET MONUMENTS ON LIBERTY STREET AS SHOWN ON THE MAP OF TRACT 5963, RECORDED IN BOOK 271 OF MAPS AT PAGE 3 WAS USED AS THE BASIS OF BEARINGS FOR THIS SURVEY.

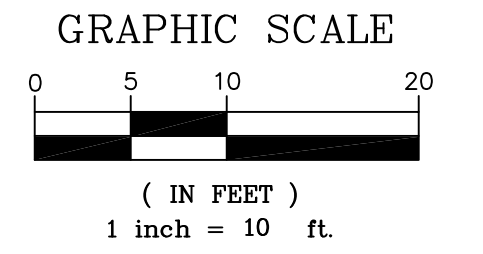

APN: 502-112-038

LEGEND	REFERENCES	REVISIONS	KISTER, SAVIO & REI, INC. LAND SURVEYORS - CIVIL ENGINEERS 3095 RICHMOND PARKWAY, SUITE 214 RICHMOND, CALIFORNIA 94806 PHONE: (510) 222-4020 FAX: (510) 222-3718 E-MAIL: info@ksrinc.net	DESCRIPTION
	FIELD BOOK No. FILE MAP: G-2 TITLE CO.: POLICY No.: DATUM: ASSUMED MSC. REF.: B-8846 R-803, R-1124	FOR: ED BIGGS SCALE: 1"=10' DATE: DECEMBER 20, 2013		
NOTE: CONTOURS BY INTERPOLATION, APPROXIMATE ONLY.		FOR: ED BIGGS SCALE: 1"=10' DATE: DECEMBER 20, 2013		EL CERRITO CALIFORNIA